

JSKD/JSMD/JSND200

Description

- 1) A package of series of two diodes.
- 2) Heat transfer through alumina ceramic and metal substrate.
- 3) Welding by vacuum welding technology, which provide high reliability.



Typical Application

AC converter, inverter and DC motor.

Absolute Maximum Ratings (Packaged into modules, unless otherwise specified, $T_{CASE}=25^{\circ}C$)

Parameter	Test Conditions	Symbol	Values				Unit
			12	16	18	20	
Operating junction temperature range		T_j	-40-150				$^{\circ}C$
Storage temperature range		T_{stg}	-40-125				$^{\circ}C$
Repetitive peak reverse voltage	$T_j=25^{\circ}C$	V_{RRM}	1200	1600	1800	2000	V
Non-repetitive peak reverse voltage	$T_j=25^{\circ}C$	V_{RSM}	1300	1700	1900	2100	V
Average on-state current	$T_C=100^{\circ}C$	$I_{F(AV)}$	200				A
Peak on-state surge current	$t_P=10ms, \sin 180^{\circ}$,	I_{FSM}	5800				A
I^2t value for fusing	$T_j=25^{\circ}C$	I^2t	168200				A^2s
Insulation voltage	A.C 50Hz(1s/1min)	V_{ISO}	3600/3000				V

Electrical Characteristics (Packaged into modules, unless otherwise specified, $T_{CASE}=25^{\circ}C$)

Parameter	Test Conditions	Symbol	Values	Unit
Peak on-state voltage	$I_F=600A, t_P=380\mu s$	V_F	≤ 1.6	V
Threshold voltage	$T_j=150^{\circ}C$	V_{TO}	≤ 0.7	V
Dynamic resistance	$T_j=150^{\circ}C$	R_d	≤ 1.0	$m\Omega$
Repetitive peak reverse current	$V_R=V_{RRM}$ $T_j=25^{\circ}C$	I_{RRM1}	≤ 100	μA
	$T_j=150^{\circ}C$	I_{RRM2}	≤ 60	mA
Thermal resistance	Junction to case	$R_{th(j-c)}$	0.16	$^{\circ}C/W$
	Case to heatsink	$R_{th(c-s)}$	0.12	

Mechanical Characteristics

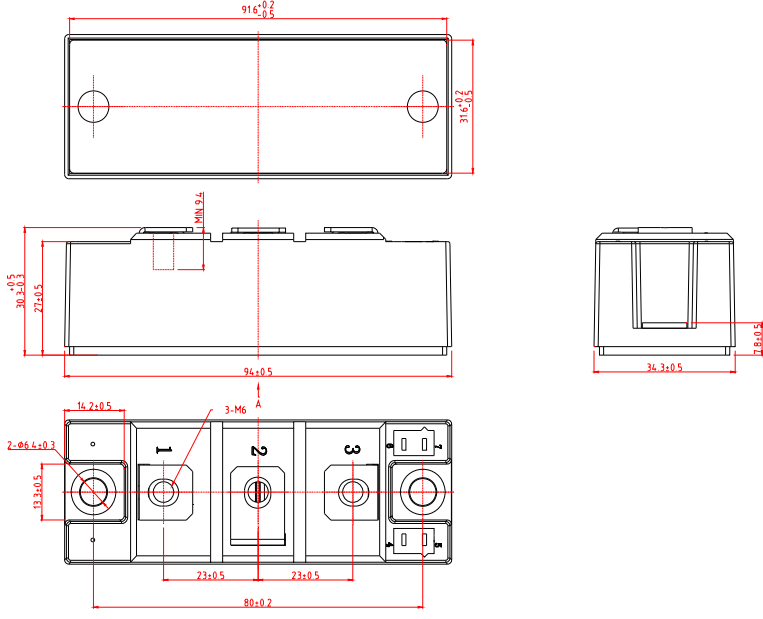
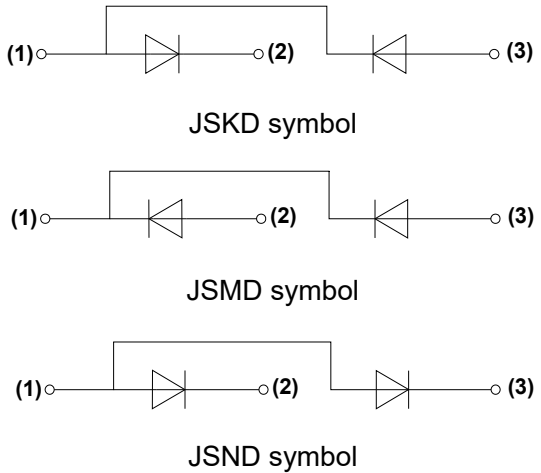
Module size	94mm×34.3mm
Module height	30.3mm
Terminal distance of (1)/(2)/(3)	23mm
Mounting torque(M5)	5±15%Nm
Terminal torque(M6)	5±15%Nm
	 <p>JSKD symbol</p> <p>JSMD symbol</p> <p>JSND symbol</p>

Instructions and Precautions

- 1) There is no severe vibration and shock in operating environment, and there should be no impurity and atmosphere which may corrode metal and damage the insulation in the air-dielectric.
- 2) The operating condition of the product can't out of range of the above parameters.
- 3) When the product is installed on the radiator, the radiator's surface should be confirmed flat, smooth, wipe clean with alcohol, and coated evenly with a layer of thermal grease which thickness is moderate on the contact surface between product and radiator. When the module is fastened on the surface of the radiator, the M5 or M6 screws and spring washers are used and fastened with 5NM torque. After the module is operated 1 hour, all screws must be refastened.
- 4) The connection with the main electrode of module can use copper, welding, socket and so on. The contact surface should be smooth and flat, which make good contact. While the connection with the control electrode of module is installed, attention should be paid to the corresponding connection of each pin. After the completion of the connection, do not plug and pull out the lead of the control electrode freely.



Ordering Information

<p>JS KD</p> <p>JieJie Semiconductor Co.,Ltd</p> <p>KD:Diode Module MD:Common Cathode Diode Module ND:Common Anode Diode Module</p>	<p>200 / 16</p> <p>$I_{F(AV)}=200A$</p>	<p>12: $V_{RSM} \geq 1300V$ 16: $V_{RSM} \geq 1700V$ 18: $V_{RSM} \geq 1900V$ 20: $V_{RSM} \geq 2100V$</p>
--	--	--

Performance Curves

FIG.1: Forward characteristics(per diode)

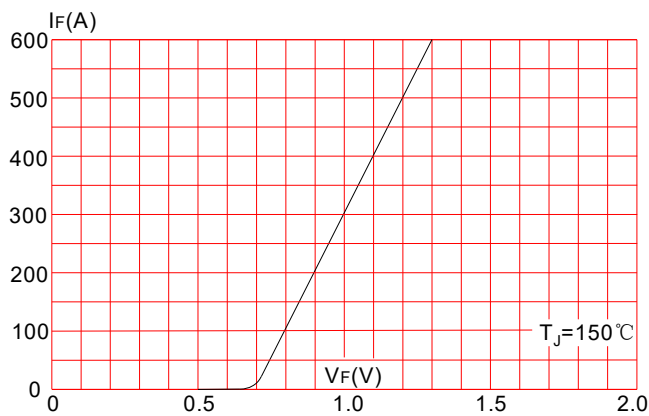

FIG.2: Peak on-state surge current

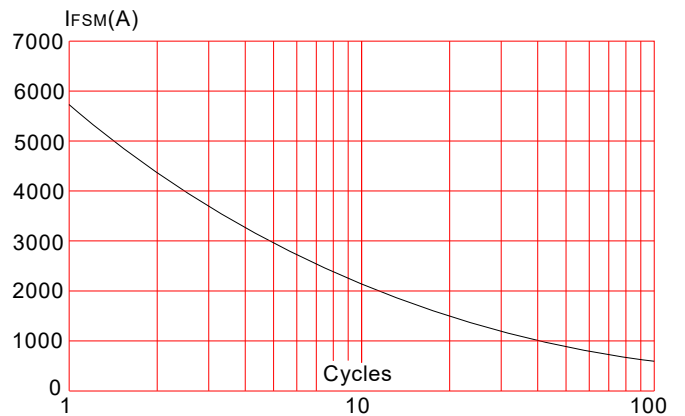

FIG.3: Forward current vs. case temperature

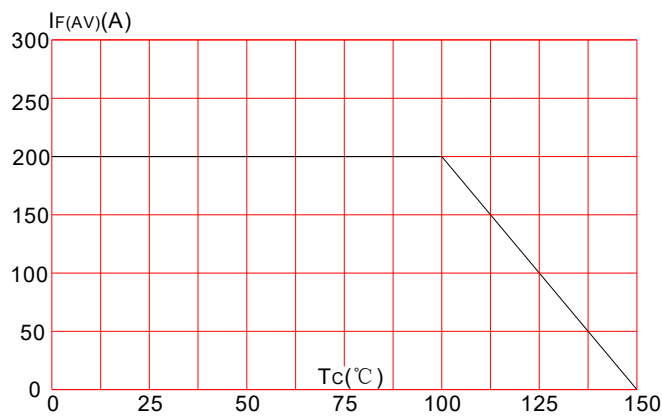
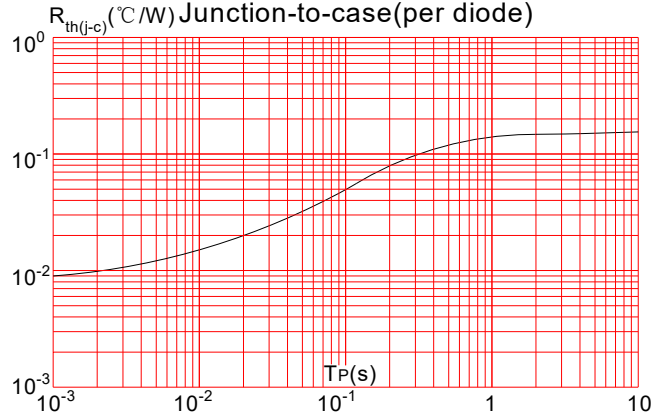

FIG.4: Maximum transient thermal impedance





Information furnished in this document is believed to be accurate and reliable. However, JieJie Semiconductor Co.,Ltd assumes no responsibility for the consequences of use without consideration for such information nor use beyond it.

Information mentioned in this document is subject to change without notice, apart from that when an agreement is signed, JieJie complies with the agreement.

Products and information provided in this document have no infringement of patents. JieJie assumes no responsibility for any infringement of other rights of third parties which may result from the use of such products and information.

This document is the sixth version which is made in 29-Aug.-2024. This document supersedes and replaces all information previously supplied.

 is registered trademarks of JieJie Semiconductor Co.,Ltd. Copyright©2024 Semiconductor Co.,Ltd. Printed All rights reserved.